

R.c. post & wall to be painted by s.o approval (Sable Brown (N 1876A) Nippon paint or equivalent)

R.c. wall to be painted by s.o approval (Nutmeats (BGG 1697P) Nippon paint or equivalent)

MESYUARAT JAWATANKUASA PUSAT SETEMPAT BIL 11/2022 BERTARIKH 14 JUN 2022 TELAH MEMUTUSKAN:

- a) *Penyediaan panel papan tanda perumahan sahaja tanpa 'Planters Box' dan tanaman landskap bagi lokasi yang mempunyai ruang di tapak yang terhad.*
- b) *Perletakkan papan tanda perumahan seperti mana yang telah ditetapkan di kawasan yang mempunyai ruang di tapak adalah seperti berikut:-*
 - i) *Papan tanda perumahan berskala besar- 'Planter Box' diganti dengan 'Concrete base' tanpa tanaman landskap.*
 - ii) *Papan tanda perumahan berskala kecil - 'Planter Box' di ganti dengan 'Concrete base' tanpa tanaman landskap.*

SAIZ KESELURAHAN	SAIZ BESAR	SAIZ KECIL
PANEL	3300mm x 250mm	2700mm x 500mm
TAPAK KONKRIT	4500mm x 2850mm	3300mm x 1000mm

PENGARAH JABATAN KEURUTERAAN	KETUA BAHAGIAN PROJEK DAN KERJA AWAM	PELAN INI TELAH DISEMAK DAN DITAPIS OLEH JAWATAN KUASA PENYEMAKAN PELAN - PELAN MAJLIS PADA: BIL:	TAJUK PROJEK PAPAN TANDA PERUMAHAN BERSKALA KECIL (1-30 UNIT RUMAH)		TYPE A
			BERDASARKAN KELULUSAN MESYUARAT JAWATANKUASA PUSAT SETEMPAT BIL 11 / 2022 BERTARIKH 14 / 6 / 2022		
		TAJUK LUKSIAN PLAN, FRONT ELEVATION, RIGHT ELEVATION, SECTION A-A, SECTION B-B	DIREKA OLEH : Halim		DILUKIS OLEH : Halim
			DISEMAK OLEH : Feb 2024	SKALA : As Show	
		NO LUKSIAN			

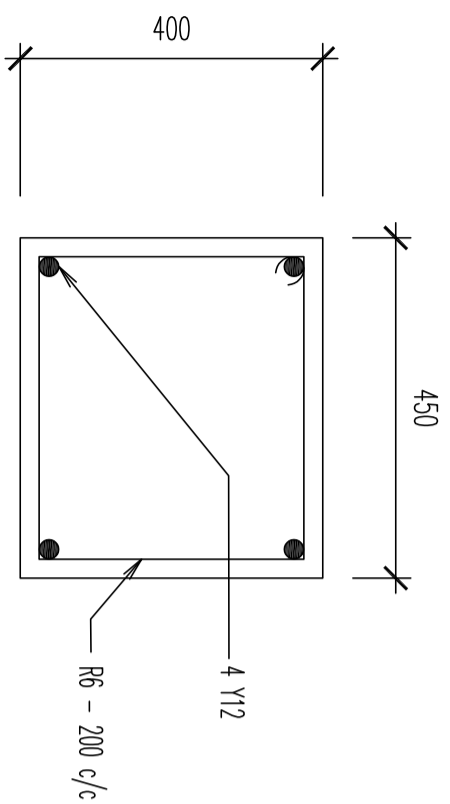

SECTION C - C

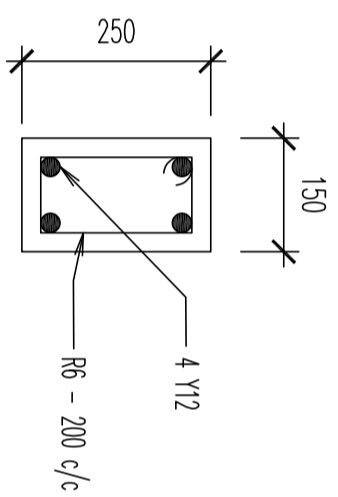

SECTION D - D

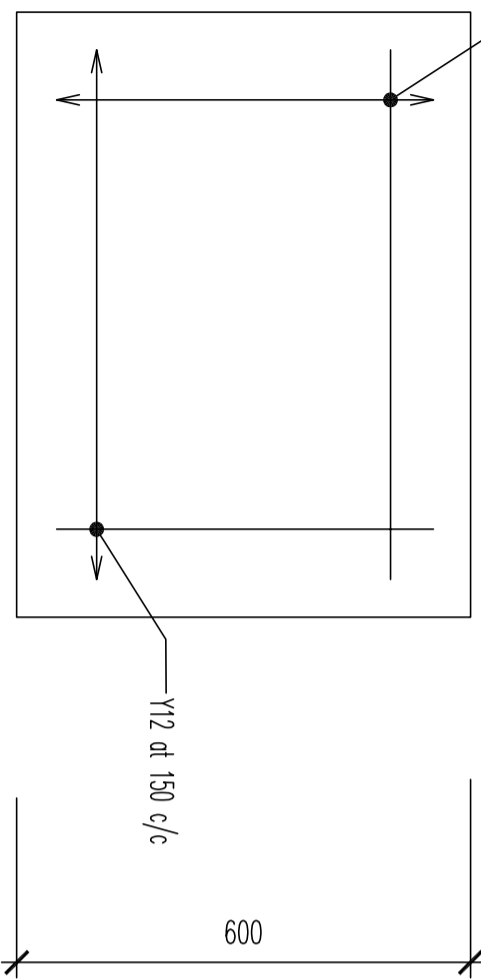
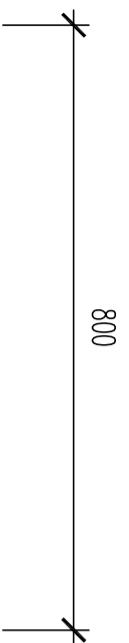
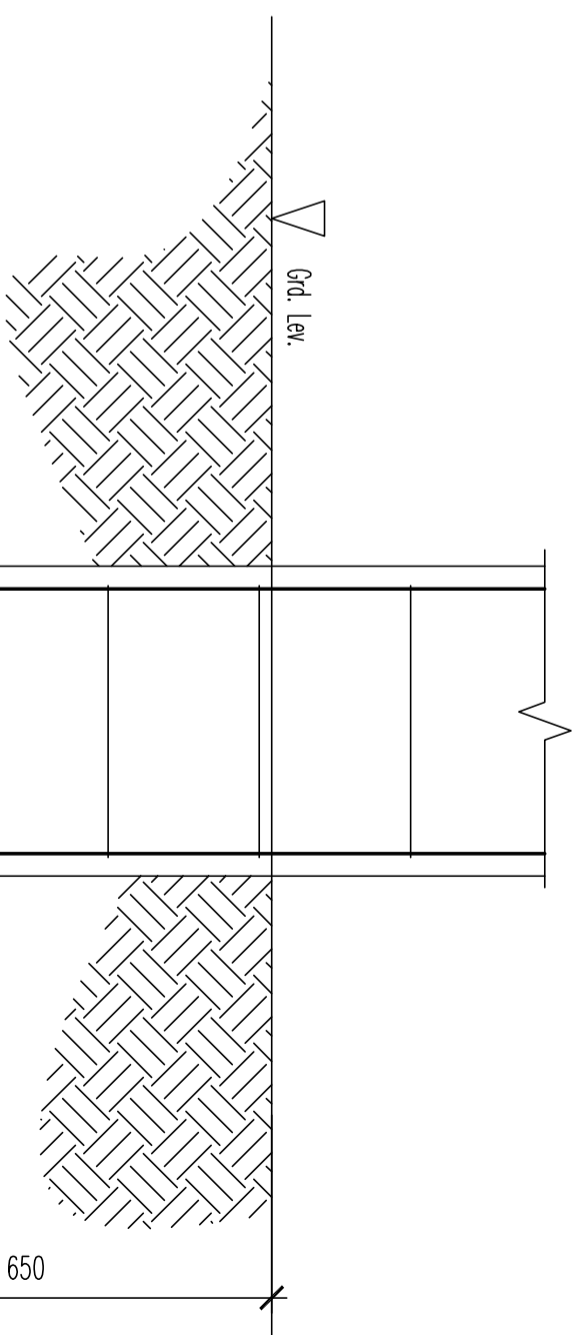

PLAN OF FOOTING

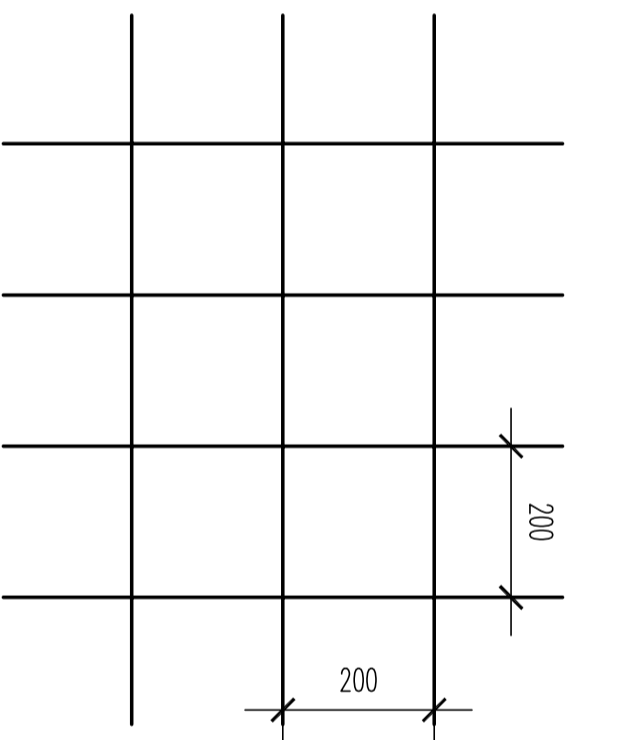

DETAIL OF FOOTING

BRC A7

PENGARAH JABATAN KEJUJUTERAAN	KETUA BAHAGIAN PROJEK DAN KERJA AWAM	PELAN INI TELAH DISEMAK DAN DITAPIS OLEH JAWATAN KUASA PENYEMAKAN PELAN - PELAN MAJLIS PADA: BIL:	TAJUK PROJEK PAPAN TANDA PERUMAHAN TYPE A BERSKALA KECIL (1-30 UNIT RUMAH) BERDASARKAN KELULUSAN MESYUARAT JAWATANKUASA PUSAT SETEMPAT BIL 11 / 2022 BERTARIKH 14 / 6 / 2022	TAJUK LUKISAN TYPICAL DETAIL OF CONG. FOOTING	DIREKA OLEH : DISEMAK OLEH : NO LUKISAN	DILUKIS OLEH : Halim TARIKH Jul 2023 SKALA : A5 Show
----------------------------------	---	---	---	--	---	---

